

SUN BOSS

BETTER
BY
DESIGN



NEXT GENERATION
BLACKOUT CASSETTE SYSTEM

With the **SunBoss** cassette you no longer need to compromise when it comes to blackout blinds – on style, appearance, performance or flexibility.

The **SunBoss** cassette has been designed for superior performance, with stylish, minimalist lines. Like all products in the SunBoss system, it is modular by design, offering more options and benefits for users and installers.

VERSATILITY FOR INSTALLERS AND USERS

- Use as cassette only or cassette plus side channels.
- Bracket or direct mounting options.
- Chain, chainless or motorised (AC or DC) operation.
- Centre link brackets provide more installation options.
- Spring Assisted, incl ZeroGravity.

DESIGNED FOR TODAY

- Stylish, modern square-lined shape.
- Metal end covers are perfectly matched to the finish off the headbox and side channel profiles.
- Specially formulated, customised colours- matte white, matte black and 20 micron clear anodised.
- Mill finish available for custom colours.

100% LIGHT BLOCKING

While the standard cassette layout uses a conventional flat base rail and side channels, there is a second configuration easily achieved that uses the same side channels to form a bottom channel, making the cassette system 360 degree wrap-around and fully light blocking. A patented corner block seamlessly joins the sections at the bottom corners to create a perfect connection.

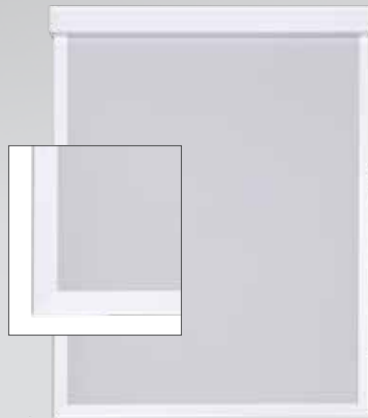

Wrap around version side channel design, 100% light blocking.



Chain, chainless or motorised (AC or DC) operation.

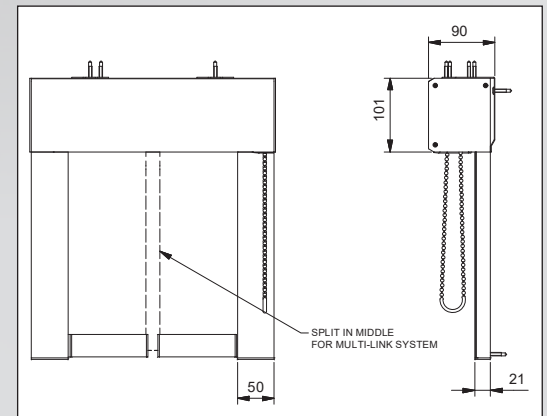

Key dimensions

**MODULAR
BY DESIGN**

With the **SunBoss** cassette you no longer need to compromise when it comes to blackout blinds – on style, appearance, performance or flexibility.

BETTER BY DESIGN

- Closure problems caused by excessive powder coat build-up are a thing of the past. The unique clasp design between the front and rear cassette profiles ensures ease of assembly no matter how much powder coat has been applied, even if sections have been double coated for colour change.
- Like all SunBoss bracket systems, a centre bracket is available for the cassette, allowing dependent or independent linked blinds to be readily installed inside the single cassette box – no joins, less light entry and easier installation.



Independent linked blinds with single headbox.

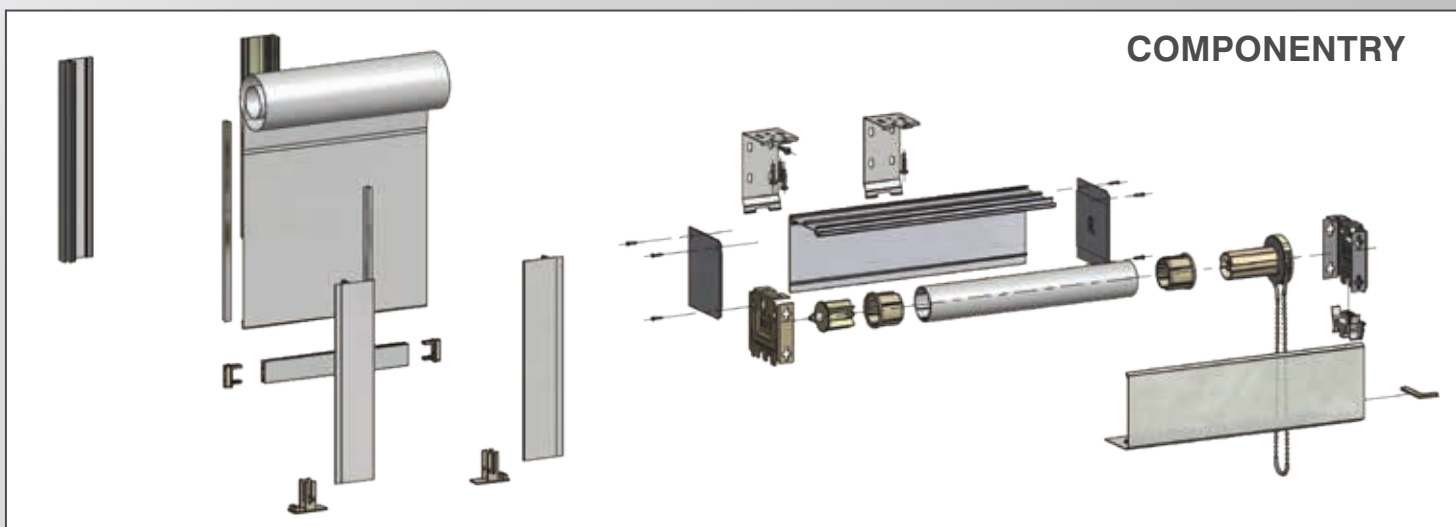

SUN BOSS BETTER
BY
DESIGN

With the **SunBoss** cassette you no longer need to compromise when it comes to blackout blinds – on style, appearance, performance or flexibility.

If you have windows bordered by uneven surfaces like brick walls, it can be difficult to fill in the light gaps with a traditional cassette - often putty needs to be used, which ruins the aesthetics of the window. The **SunBoss** cassette has an overlapping function just for this situation - the side channels extend by 10mm to hide the fillers and beautify the installation.



WITHOUT EXTENSION

The light gaps need to be filled with putty, giving an uneven, messy finish.



WITH EXTENSION

The **SunBoss** cassette extends over the filler for a clean, stylish look.



World class fully-featured systems designed in Australia.

Melbourne-based Blindware is a supplier of internal blind systems and components for the world market. Since being established in 2006, Blindware has emerged to become one of Australia's leading independent hardware system suppliers, as well as a significant supplier of fabrics and motorisation systems.

At Blindware we take a holistic view of the blind, which gives us a unique ability to develop products that assist our customers in efficient and effective manufacture, installation and use of internal blind systems. Our systems are smart, modular, and designed to make our customer's lives easier the world over.

We have a complete range of roller blind and other systems and products, including:

- Screen Fabric
- Blockout fabrics
- Commercial fabrics
- Panel track
- Wood venetian
- Aluminium venetian
- Accessories
- Motorisation

Contact your local rep

NSW: 0434 686 789 **VIC:** 0416 252 694 **QLD:** 0408 304 709

All other enquiries: (03) 9876 0400 sales@blindware.com.au

Blindware Pty Ltd

Unit 1/3 Dunlop Crt, Bayswater 3153 Tel: (03) 9876 0400 Fax: (03) 9720 2746

Email: sales@blindware.com.au

Web: www.blindware.com.au